

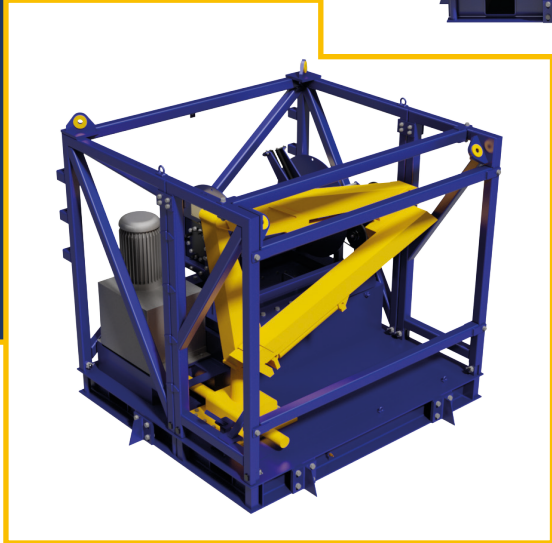

Mk3 SELF BALLAST CRANE LARS



The Mk3 Self Ballast Crane Launch and Recovery System (LARS) is a compact system with a small footprint, which offers a plug in and play quick start operating. Designed to launch off an Oil and Gas Platform or Jack-Up without the need to secure the Mk3 to the deck.

For security and transit the crane is stowed away with the ROV safely housed underneath, the gates are locked in place around the system. The gates can be folded back and locked open during operation.

The ballast tank fitted to the rear of the Mk3 allows for 650liters of (fresh / salt) water to be held providing a fully counter-balanced system; removing the need for welding to the deck.

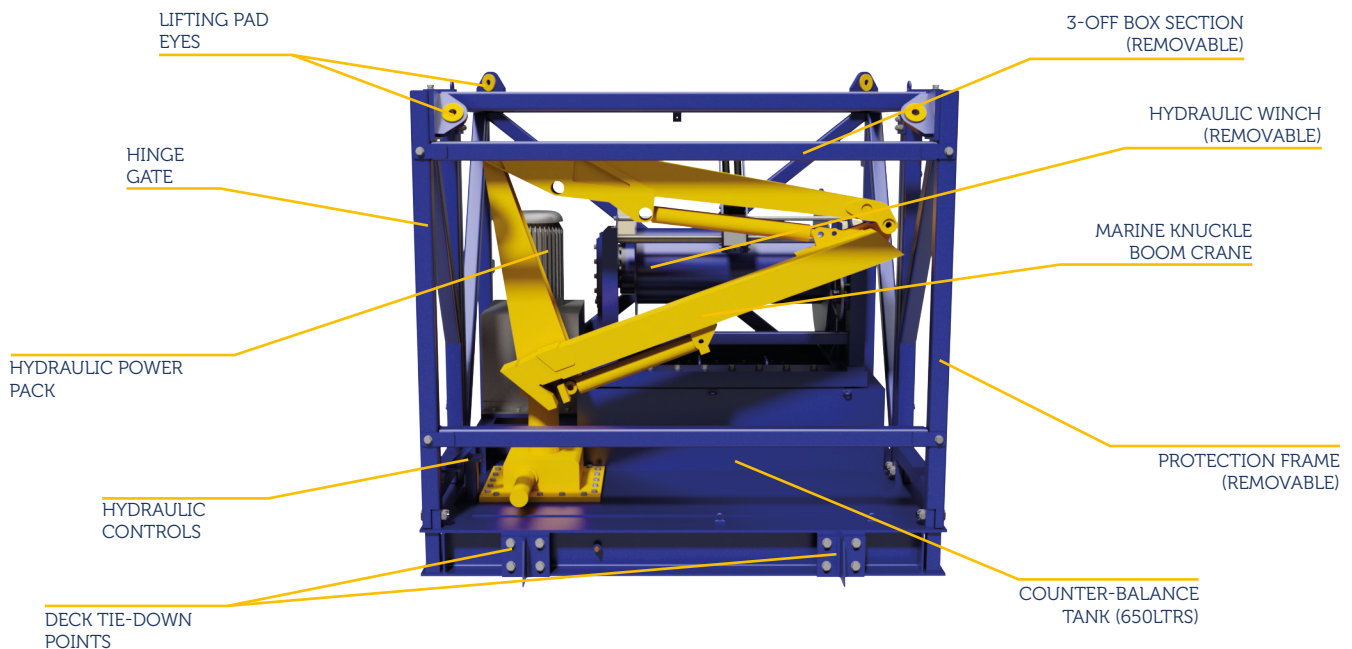

Outreach Offshore Ltd provide Launch and Recovery Systems (LARS) that feature a combined umbilical winch and overboarding system on a base frame. Our LARS are designed specifically for deploying and recovering tethered powered objects, such as: towed arrays, ROVs or any other underwater vehicles.

LAUNCH & RECOVERY Mk3 SELF BALLAST CRANE LAR



SPECIFICATIONS

Dimensions (mm):	2,100 (L) x 2,550 (W) x 2,184 (H) as standard
Launch SWL (kgs):	Up to 605
Outreach (m):	Up to 5.6
Operating Conditions:	Lloyds Sea State 6, 3.9m Significant Wave Height
Power Requirements:	380-460V AC 3Ph 50/60Hz
Rating Options:	Safe Area or Zone 2 ATEX
Design Temperature:	-20°C to +50°C
Certification:	BS EN 12079 for offshore lifting, Lloyd's Code for Lifting Appliances in a Marine Environment
Max. Drum Capacity:	<ul style="list-style-type: none">• 430m x 25-26mm• 700m x 20-21mm• 1,100m x 14-15mm• 2,100m x 10-11mm

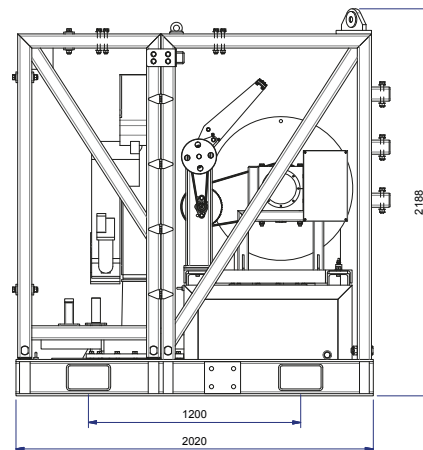
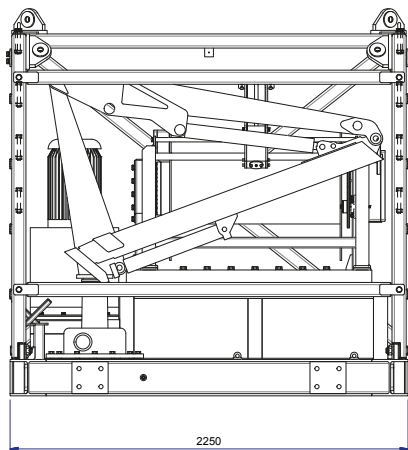
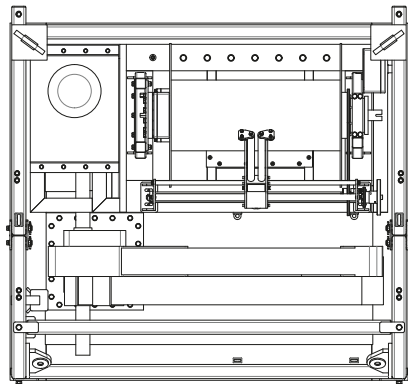

Dimensions shown in this leaflet do not always correspond to the standard specifications. Design and specifications are subject to change without prior notice. Dimensions may vary, subject to technical changes.